

MODELS Y600 AND Y600L CHASSIS 6T40Z AND 6T41Z

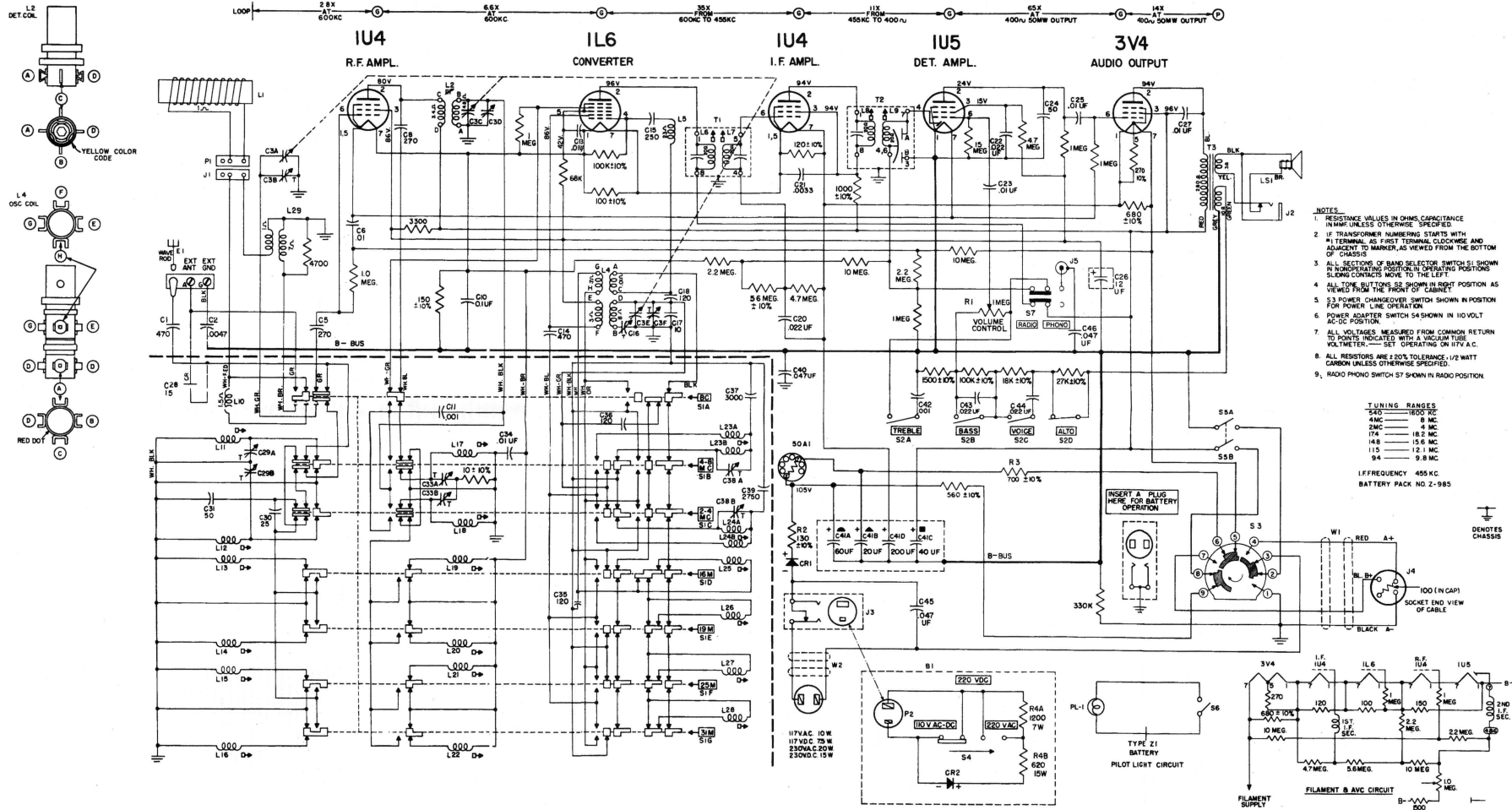

REAR VIEW OF BAND SELECTOR SWITCH.

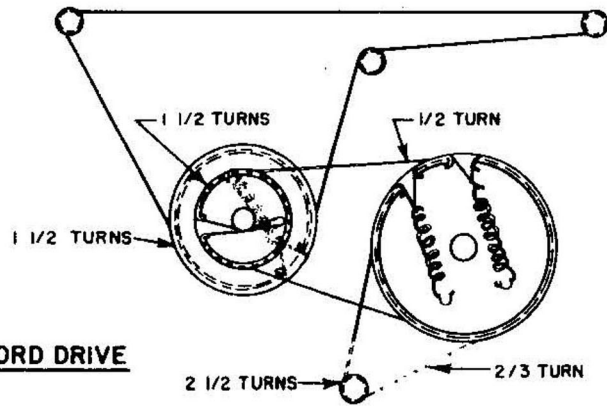

DIAL CORD DRIVE

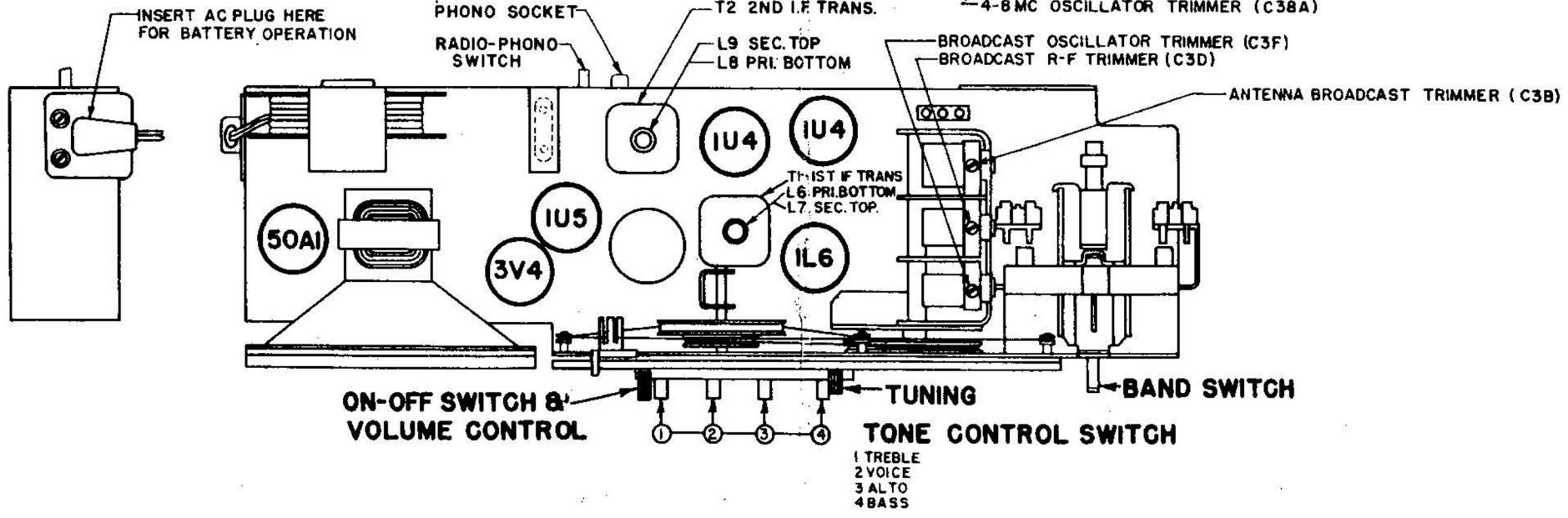
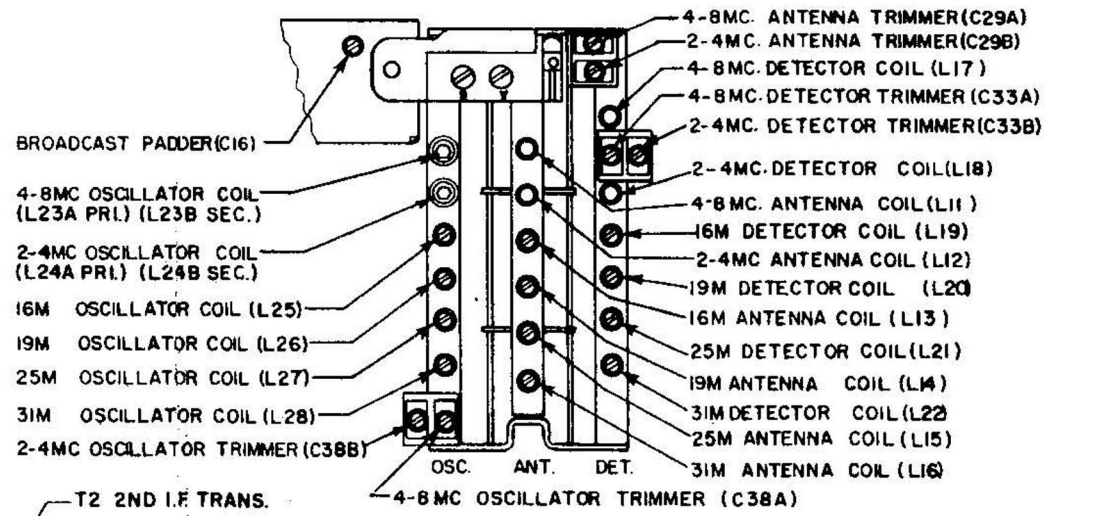

TO THE SERVICE MAN:

Chassis 6T40Z features a high gain tuned RF stage ahead of a conventional superheterodyne circuit with band spread tuning on the 31, 25, 19 and 16 meter bands. There are two continuous coverage bands, one covering 2-4 megacycles and one covering 4-8 megacycles.

If removal of the chassis from the cabinet ever becomes necessary this should be done with care.

The alignment of chassis 6T40Z is conventional. However, care must be exercised when making adjustments, and the alignment procedure must be followed exactly. Set the chassis over a metal plate approximately the same distance the battery pack is from the bottom of the chassis when it is in the cabinet. This procedure will introduce the approximate amount of metal in the field of the RF and oscillator coils as when the chassis is in the cabinet. A signal generator of reasonable accuracy and good attenuation must be used. An output meter (AC) of the copper oxide rectifier type with a range of 1 to 30 volts in several steps is necessary to get accurate output readings. Alignment wrenches should be of the non-metallic type, especially when making adjustments of the higher frequencies.

When reinstalling the chassis in the cabinet be careful not to disturb the cabling between the short wave coil assembly and chassis. Tune in a weak broadcast signal near 1400 Kc. and touch up trimmer C3B. This will insure maximum performance after alignment.

The I.F. transformers incorporated in this receiver are of the new permeability tuned type. The advantage of an I.F. transformer of this type is its extreme stability under various humidity and temperature conditions. The upper coil is the secondary and the lower the primary. When adjusting these I.F. transformers the tuning wrench 68-19 can be inserted into the top slug, rotated until maximum output is obtained and then dropped down to the lower slug and the same operation repeated. The tuning wrench is so designed that tuning one slug does not affect the adjustment of the other.

Thermal Regulator Tube 50A1 is an automatic rheostat designed to keep the current in a circuit at a definite value. Should the supply voltage change, either upward or downward, the Thermal Regulator will automatically increase or decrease its resistance to compensate for this change and keep the current thru the controlled circuit at a constant value.

As used in the Y600, the controlled circuit consists of the filament of the five vacuum tubes connected in series. A constant current thru these filaments is equivalent to a constant voltage applied across them.

The Thermal Regulator tube is capable of performing its function because of its peculiar electric thermal characteristics. Basically the tube consists of a fine iron wire filament hermetically sealed in a hydrogen atmosphere. By balancing the temperature resistance curve of the wire against the thermal conductivity curve of the gas, it is possible to make a unit that automatically changes its resistance to

ALIGNMENT PROCEDURE

OPER.	CONNECT OSCILLATOR TO DUMMY ANTENNA	INPUT SIGNAL FREQ.	BAND	SET DIAL AT	TRIMMERS	PURPOSE
1	Positive lead of signal generator to converter grid through a .1 Mfd. condenser & negative lead to negative filament of 1L6 tube.	455 Kc	BC	600 Kc	L 6,7,8,9	Align I.F.
2	One turn loop coupled loosely to broadcast wavemagnet	1600 Kc	BC	1600 Kc	C3F	Set oscillator to scale
3		1400 Kc	BC	1400 Kc	C3D	Alignment of BC Der.
4		1400 Kc	BC	1400 Kc	C3B	Alignment of BC ant.
5*		600 Kc	BC	600 Kc	Rock C16	Alignm't of BC at 600 Kc
6		7.8 Mc	4-8 Mc	7.8 Mc	C38A, C33A, C29A	Alignment of S. W. Oscillator Detector and Antenna.
7*	4.2 Mc	4-8 Mc	4.2 Mc	Rock L23B		
8	REPEAT OPERATIONS 6 & 7					
9	3.9 Mc	2-4 Mc	3.9 Mc	C38B, C33B, C29B		
10*	2.1	2-4 Mc	2.1 Mc	Rock L24B		
11	REPEAT OPERATIONS 9 & 10					
12	17.8 Mc	16 Meters	17.8 Mc	L 25, L 19, L 13		
13*	15.2	19 Meters	15.2	L 26, L 20, L 14		
14	11.8 Mc	25 Meters	11.8	L 27, L 21, L 15		
15*	9.6 Mc	31 Meters	9.6 Mc	L 28, L 22, L 16		

* NOTE: Rock Tuning Condenser When Making Alignment Under Operations 5, 7, 10, 12, 13, 14 & 15.